

# 7500 SERIES

.295" (7.5mm) X .197" (5.0mm) PITCH WIRE TO WIRE CONNECTOR

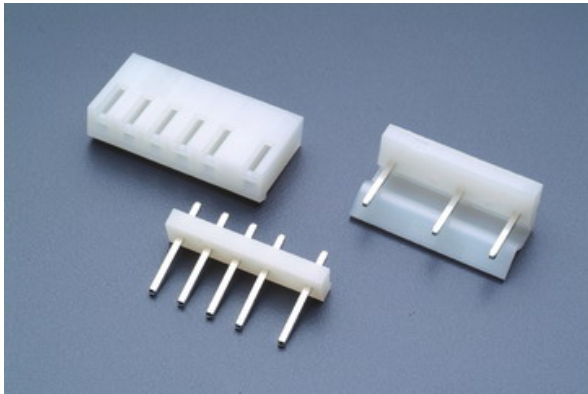

## Specifications

Current rating: 5A AC, DC

Voltage rating: 250V AC, DC

Temperature range: -25°C to +85°C  
(including temperature rise)

Contact resistance: Initial value/10mΩ Max.

After environmental testing/10mΩ Max.

Insulation resistance: 500MΩ MIN.

Withstanding voltage: 1000V AC/minute

Applicable wire: AWG#18-22

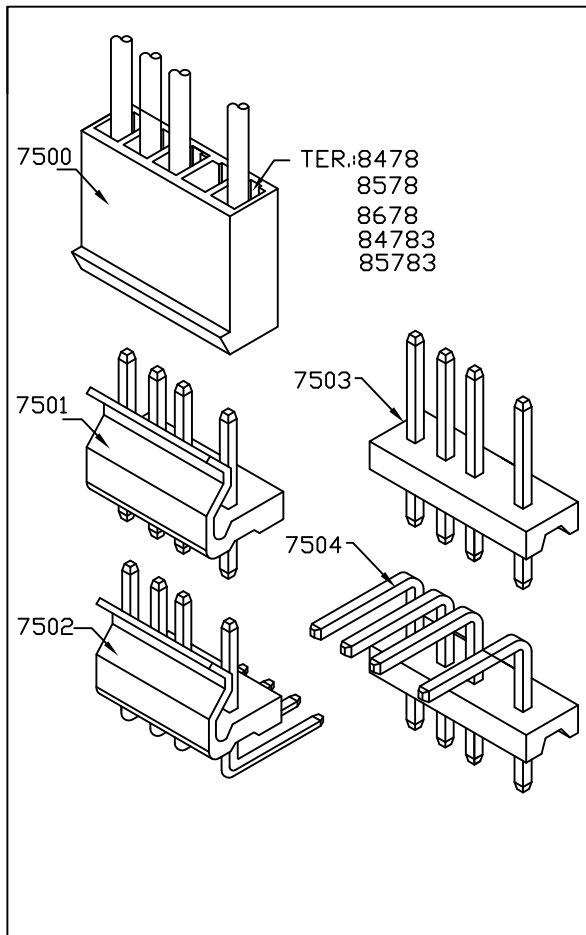

## Assembly layout

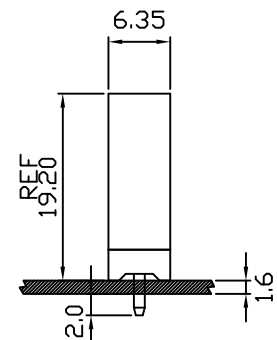
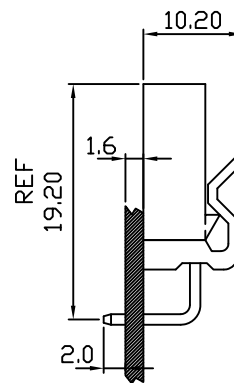
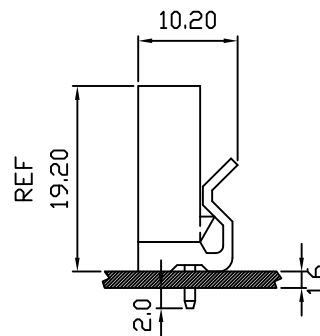

# 7500 .295" (7.5mm) X .197" (5.0mm) CRIMP HOUSING

unit:mm

## Features:

- \* MAT'L: NYLON 66 UL94V-2
- \* MATES WITH 8478 8578 8678 SERIES TERMINAL
- \* ACCEPTS WITH: 7501 7502 7503 7504 SERIES WAFER

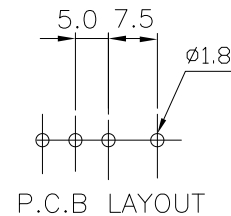
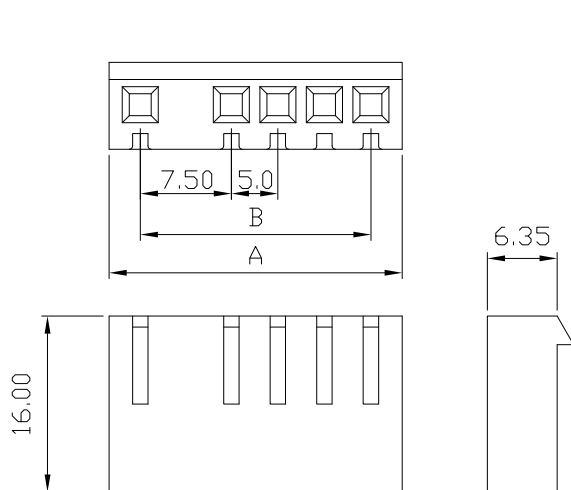

PART NO.	A	B
7500-02	12.4	7.50
7500-03	17.4	12.50
7500-04	22.3	17.50
7500-05	27.3	22.50
7500-06	32.2	27.50
7500-07	37.2	32.50
7500-08	42.2	37.50
7500-09	47.2	42.50
7500-10	52.2	47.50

# 7501 .295" (7.5mm) X .197" (5.0mm) PITCH Headers-Straight

unit:mm

## Features:

- \* MAT'L: BODY: NYLON 66 UL94V-2  
PINS: BRASS TIN PLATED
- \* MATES WITH 7500 SERIES HOUSING

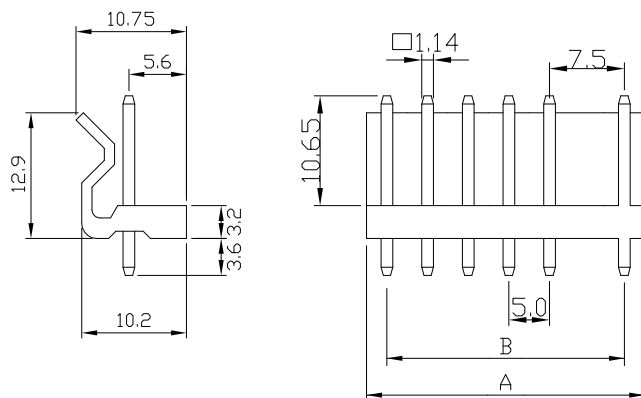
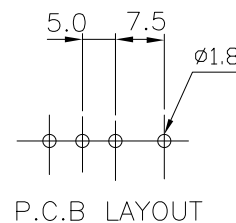

PART NO.	A	B
7501-02	12.5	7.5
7501-03	17.5	12.5
7501-04	22.5	17.5
7501-05	27.5	22.5
7501-06	32.5	27.5
7501-07	37.5	32.5
7501-08	42.5	37.5
7501-09	47.5	42.5
7501-10	52.5	47.5

# 7502 .295" (7.5mm) X .197" (5.0mm) PITCH Headers-Right Angle

Features:

unit:mm

- \* MAT'L: BODY: NYLON 66 UL94V-2  
PINS: BRASS TIN PLATED
- \* MATES WITH 7500 SERIES HOUSING

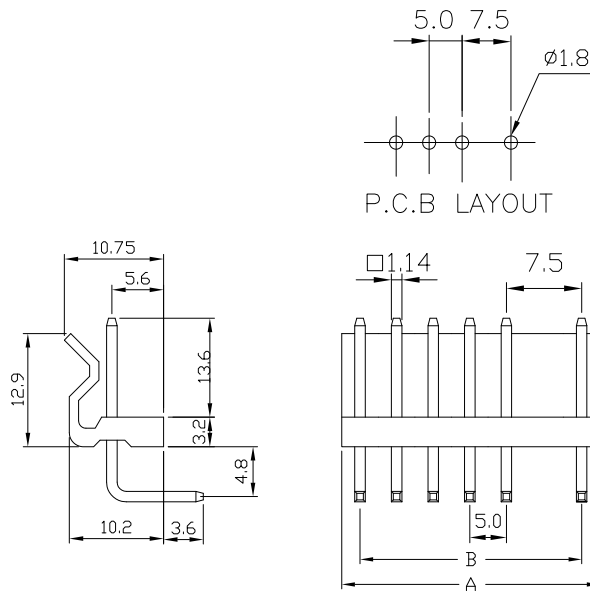

PART NO.	A	B
7502-02	12.5	7.5
7502-03	17.5	12.5
7502-04	22.5	17.5
7502-05	27.5	22.5
7502-06	32.5	27.5
7502-07	37.5	32.5
7502-08	42.5	37.5
7502-09	47.5	42.5
7502-10	52.5	47.5

# 7503 .295" (7.5mm) X .197" (5.0mm) PITCH Headers-Straight

Features:

unit:mm

- \* MAT'L: BODY: NYLON 66 UL94V-2  
PINS: BRASS TIN PLATED
- \* MATES WITH 7500 SERIES HOUSING

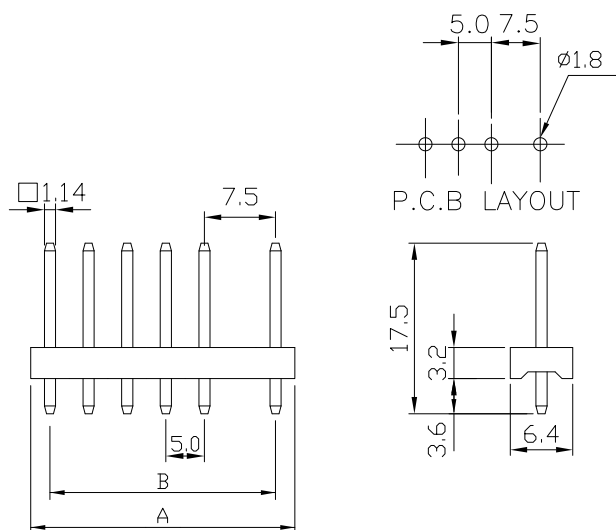

PART NO.	A	B
7503-02	12.5	7.5
7503-03	17.5	12.5
7503-04	22.5	17.5
7503-05	27.5	22.5
7503-06	32.5	27.5
7503-07	37.5	32.5
7503-08	42.5	37.5
7503-09	47.5	42.5
7503-10	52.5	47.5

# 7504 .295" (7.5mm) X .197" (5.0mm) PITCH Headers-Right Angle

Features:

unit:mm

- \* MAT'L: BODY: NYLON 66 UL94V-2  
PINS: BRASS TIN PLATED
- \* MATES WITH 7500 SERIES HOUSING

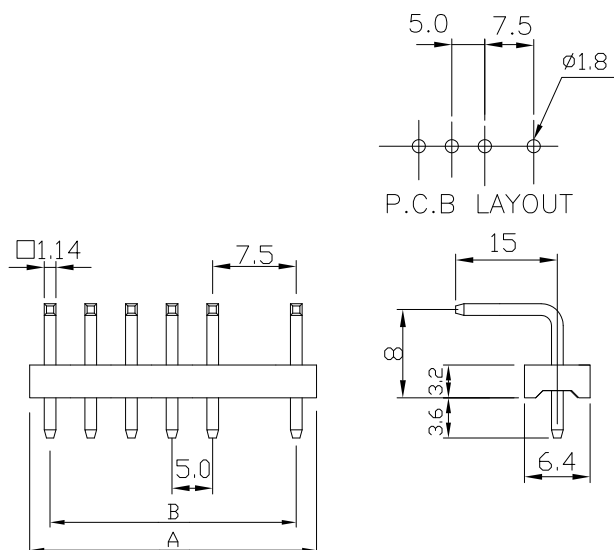

PART NO.	A	B
7504-02	12.5	7.5
7504-03	17.5	12.5
7504-04	22.5	17.5
7504-05	27.5	22.5
7504-06	32.5	27.5
7504-07	37.5	32.5
7504-08	42.5	37.5
7504-09	47.5	42.5
7504-10	52.5	47.5