

M125H SERIES

.049" (1.25mm) PITCH WIRE TO BOARD CONNECTS

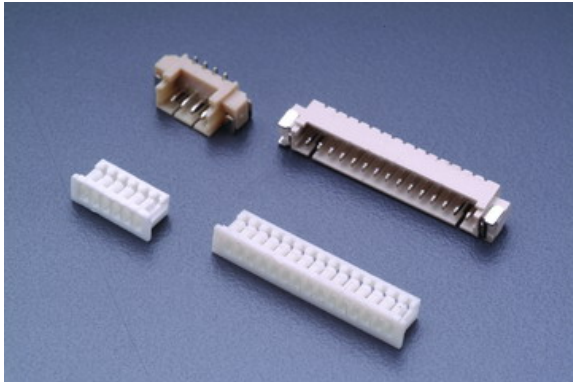

Specifications

Current rating: 1A AC,DC

Voltage rating: 30V AC,DC

Temperature range: -25°C to $+85^{\circ}\text{C}$
(including temperature rise)

Contact resistance: Initial value/10m Ω Max.

After environmental testing/20m Ω Max.

Insulation resistance: 500M Ω MIN.

Withstanding voltage: 500V AC/minute

Applicable wire: AWG#28-32

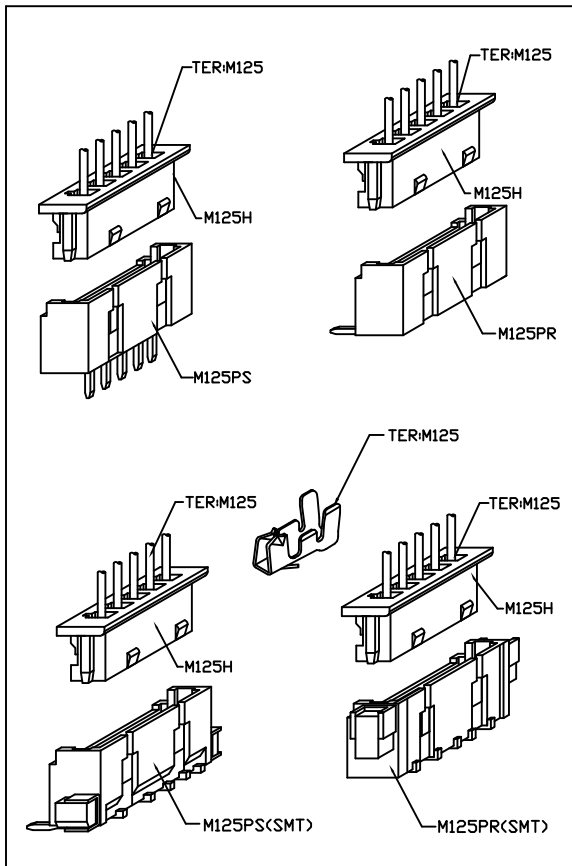

Assembly layout

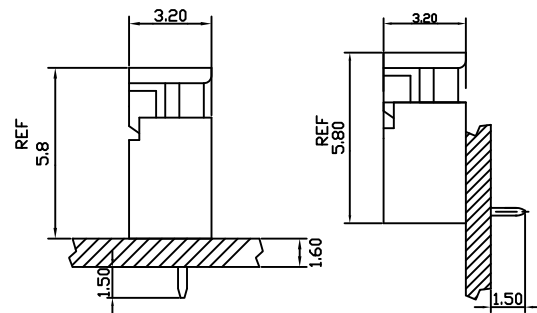

DIP TYPE

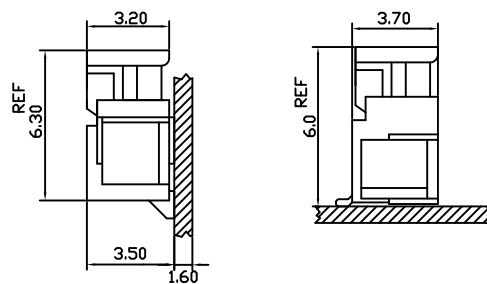

SMT TYPE

M125H .049"(1.25mm) PITCH CRIMP HOUSING

unit:mm

Features:

- * MAT'L: PBT UL94V-0
- * MATES WITH: M125 SERIES TERMINAL
- * ACCEPTS WITH: M125PS, M125PR SERIES WAFER

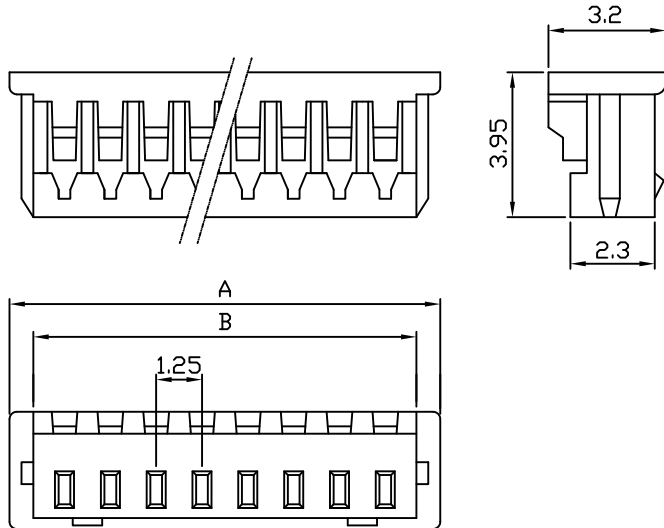

PRAT NO.	A	B
M125H-02	4.20	2.95
M125H-03	5.45	4.20
M125H-04	6.70	5.45
M125H-05	7.95	6.70
M125H-06	9.20	7.95
M125H-07	10.45	9.20
M125H-08	11.70	10.45
M125H-09	12.95	11.70
M125H-10	14.20	12.95
M125H-11	15.45	14.20
M125H-12	16.70	15.45
M125H-13	17.95	16.70
M125H-14	19.20	17.95
M125H-15	20.35	19.20

M125 .049" (1.25mm) PITCH CRIMP TERMINAL

unit:mm

Features:

- * THICKNESS: 0.15mm
- * MAT'L: PHOSPHOR BRONZE TIN PLATED
- * MATES WITH: M125H SERIES HOUSING
- * ACCEPTS WITH: M125PS & M125PR SERIES WAFER

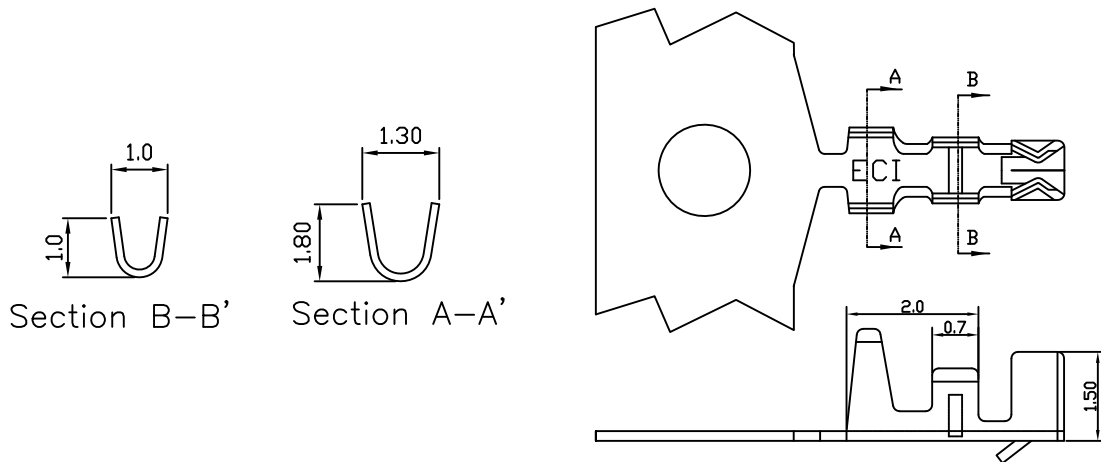

PART NO.	WIRE RANGE	INSULATION O.D.	MATERIAL	FINISH	QTY/REEL
M125	AWG#28-32	∅1.0mm MAX	PHOSPHOR BRONZE	Tin-plated	25,000

M125PS .049" (1.25mm) PITCH Headers—Straight

Features:

unit:mm

- * MAT'L: BODY: NYLON 6T UL 94V-0
PINS: BRASS TIN PLATED
- * MATES: M125H SERIES HOUSING
- * ACCEPTS WITH: M125 SERIES TERMINAL

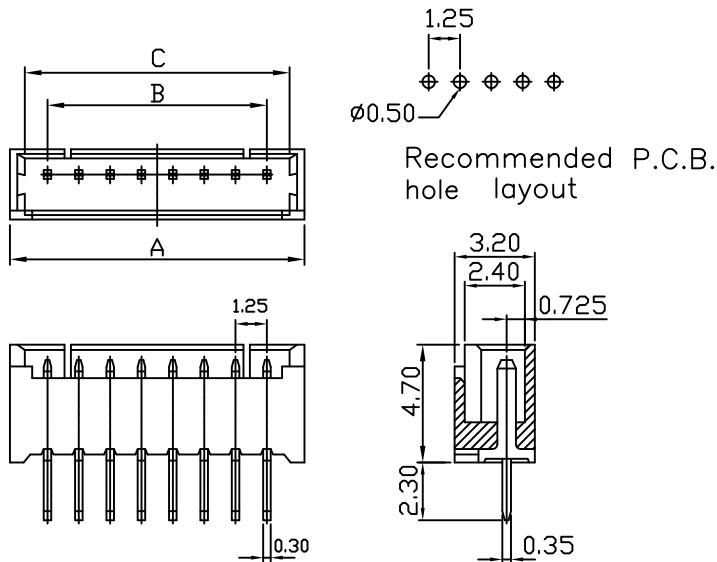

PART NO.	Dim A	Dim B	Dim C
M125PS-02	4.25	1.25	3.05
M125PS-03	5.50	2.50	4.30
M125PS-04	6.75	3.75	5.55
M125PS-05	8.00	5.00	6.80
M125PS-06	9.25	6.25	8.05
M125PS-07	10.50	7.50	9.30
M125PS-08	11.75	8.75	10.55
M125PS-09	13.00	10.00	11.80
M125PS-10	14.25	11.25	13.05
M125PS-11	15.50	12.50	14.30
M125PS-12	16.75	13.75	15.55
M125PS-13	18.00	15.00	16.80
M125PS-14	19.25	16.25	18.05
M125PS-15	20.50	17.50	19.30

M125PR .049" (1.25mm) PITCH Headers—Right Angle

Features:

unit:mm

- * MAT'L: BODY: NYLON 6T UL 94V-0
PINS: BRASS TIN PLATED
- * MATES: M125H SERIES HOUSING
- * ACCEPTS WITH: M125 SERIES TERMINAL

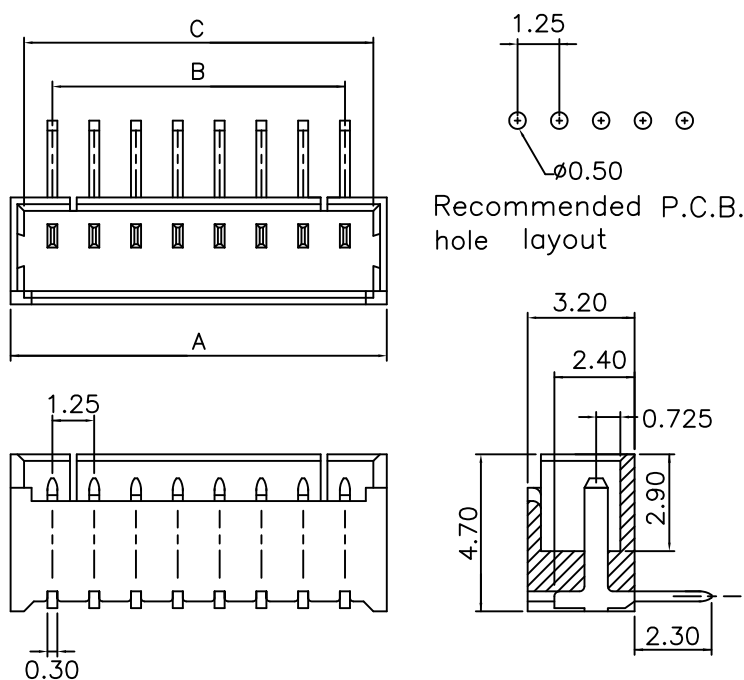

PART NO.	Dim A	Dim B	Dim C
M125PR-02	4.25	1.25	3.05
M125PR-03	5.50	2.50	4.30
M125PR-04	6.75	3.75	5.55
M125PR-05	8.00	5.00	6.80
M125PR-06	9.25	6.25	8.05
M125PR-07	10.50	7.50	9.30
M125PR-08	11.75	8.75	10.55
M125PR-09	13.00	10.00	11.80
M125PR-10	14.25	11.25	13.05
M125PR-11	15.50	12.50	14.30
M125PR-12	16.75	13.75	15.55
M125PR-13	18.00	15.00	16.80
M125PR-14	19.25	16.25	18.05
M125PR-15	20.50	17.50	19.30

M125PR(SMT) .049" (1.25mm) PITCH Headers—Right Angle

Features:

unit:mm

- * MAT'L: BODY: NYLON 6T UL94V-0
PINS: BRASS TIN PLATED
- * MATES WITH: M125H SERIES HOUSING
- * ACCEPTS WITH: M125 SERIES TERMINAL

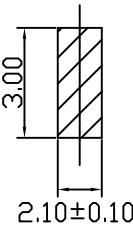
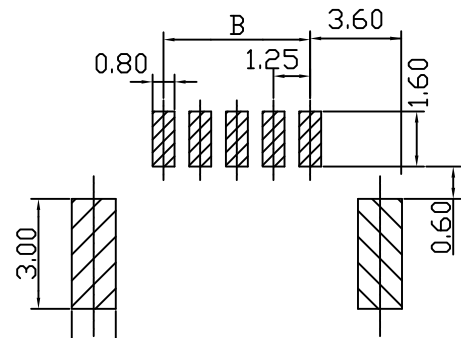
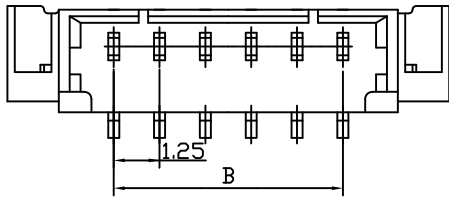

P.C.B. layout

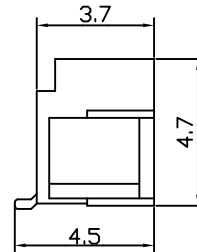
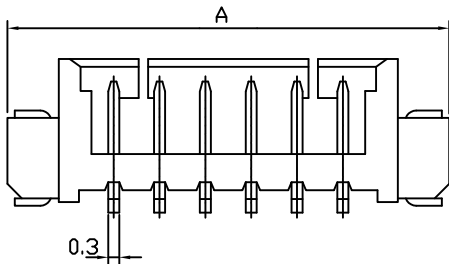

PART NO.	Dim A	Dim B	PCS/REEL
M125PR-02	7.75	1.25	1.000
M125PR-03	9.00	2.50	1.000
M125PR-04	10.25	3.75	1.000
M125PR-05	11.50	5.00	1.000
M125PR-06	12.75	6.25	1.000
M125PR-07	14.00	7.50	1.000
M125PR-08	15.25	8.75	1.000
M125PR-09	16.50	10.00	1.000
M125PR-10	17.75	11.25	1.000
M125PR-11	19.00	12.50	1.000
M125PR-12	20.25	13.75	1.000
M125PR-13	21.50	15.00	1.000
M125PR-14	22.75	16.25	1.000
M125PR-15	24.00	17.50	1.000

M125PS(SMT) .049" (1.25mm) PITCH Headers–Straight

unit:mm

Features:

- * MAT'L: BODY: NYLON 6T UL94V-0
PINS: BRASS TIN PLATED
- * MATES WITH: M125H SERIES HOUSING
- * ACCEPTS WITH: M125 SERIES TERMINAL

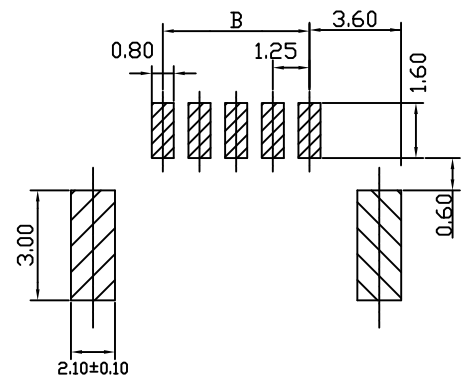
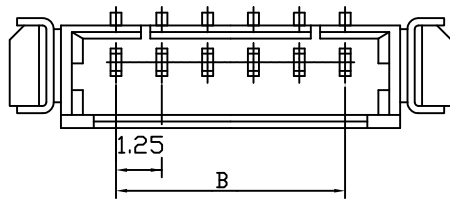

P.C.B. layout

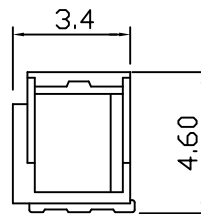
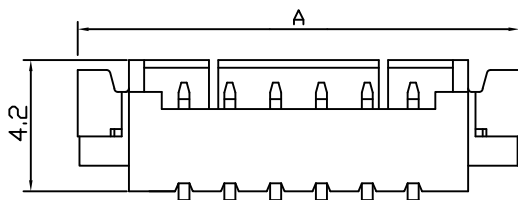

PART NO.	Dim A	Dim B	PCS/REEL
M125PS-02	7.75	1.25	1,000
M125PS-03	9.00	2.50	1,000
M125PS-04	10.25	3.75	1,000
M125PS-05	11.50	5.00	1,000
M125PS-06	12.75	6.25	1,000
M125PS-07	14.00	7.50	1,000
M125PS-08	15.25	8.75	1,000
M125PS-09	16.50	10.00	1,000
M125PS-10	17.75	11.25	1,000
M125PS-11	19.00	12.50	1,000
M125PS-12	20.25	13.75	1,000
M125PS-13	21.50	15.00	1,000
M125PS-14	22.75	16.25	1,000
M125PS-15	24.00	17.50	1,000