

E761H/E661H SERIES

WIRE TO WIRE CONNECTOR

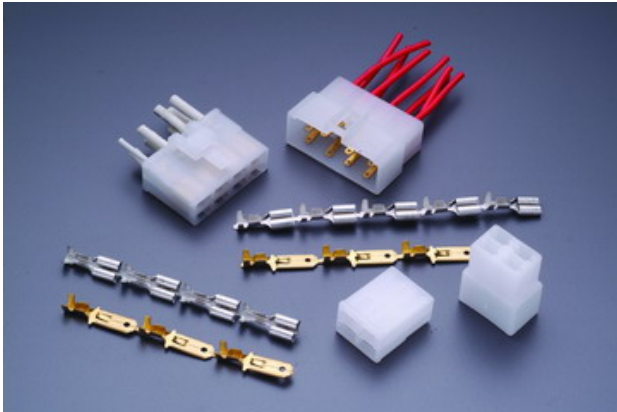

Specifications

Current rating: 5A AC,DC

Voltage rating: 250V AC,DC

Temperature range: -25°C to $+85^{\circ}\text{C}$
(including temperature rise)

Contact resistance: Initial value/10 $\text{m}\Omega$ Max.

After environmental testing/20 $\text{m}\Omega$ Max.

Insulation resistance: 500 $\text{M}\Omega$ MIN.

Withstanding voltage: 1000V AC/minute

Applicable wire: AWG#18-22

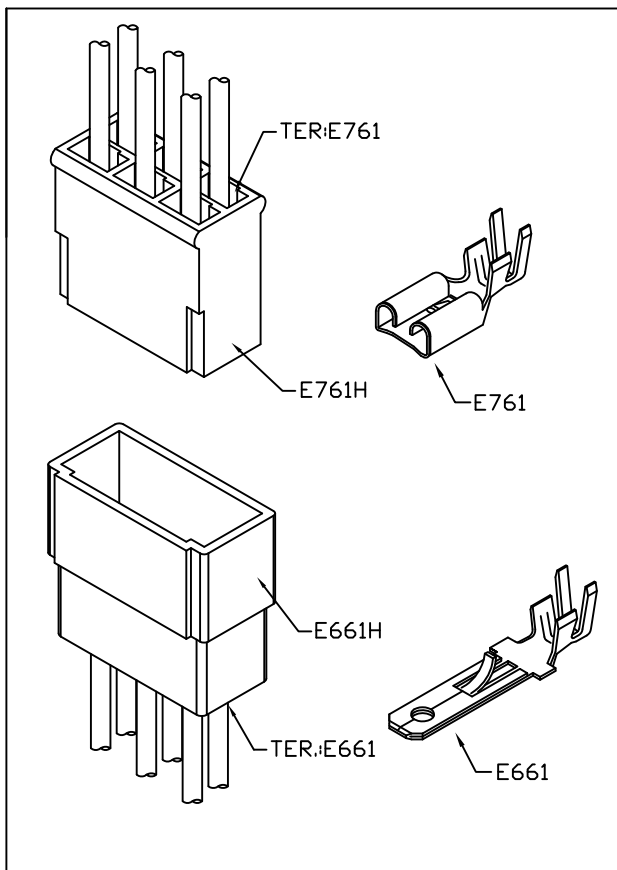

Assembly layout

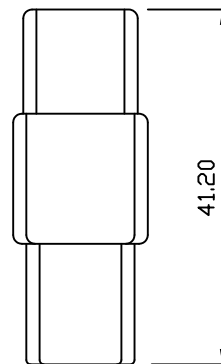

WIRE TO WIRE

E761 CRIMP TERMINAL

Features:

unit:mm

- * THICKNESS: 0.3mm
- * MAT'L: BRASS
- * MATES: E761H E761H-K E761H-S SERIES HOUSING

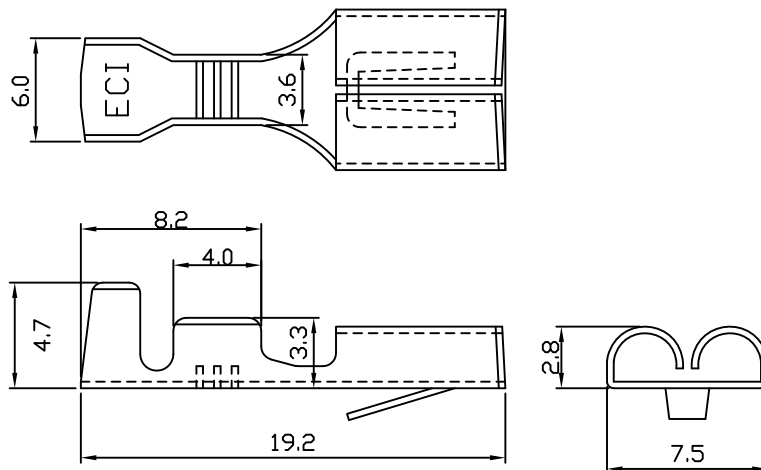

PART NO.	WIRE RANGE	INSULATION O.D.	MATERIAL	FINISH	QTY/REEL
E761	AWG#18-#22	φ3.8~φ2.0mm	BRASS	—	5,000

E661 CRIMP TERMINAL

Features:

unit:mm

- * THICKNESS: 0.4mm
- * MAT'L: BRASS
- * TREATMENT: CHEMICAL GRADING
- * MATES WITH: E761 SERIES
TERMINAL
- * ACCEPTS WITH: E661H E661H-K
E661H-S SERIES HOUSING

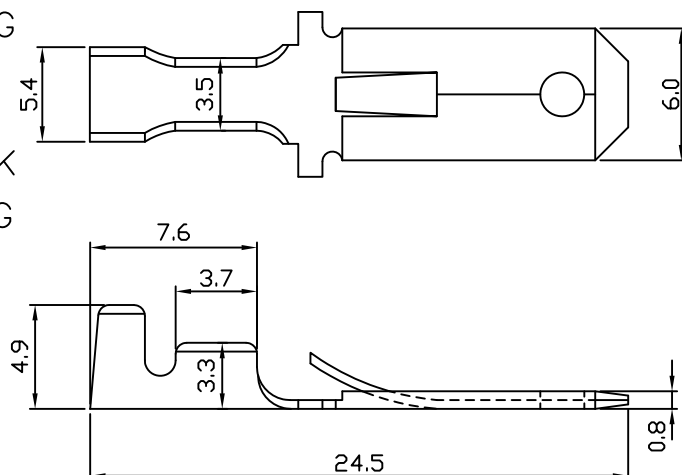

PART NO.	WIRE RANGE	INSULATION O.D.	MATERIAL	FINISH	QTY/REEL
E661	AWG#18-#22	φ3.8~φ2.0mm	BRASS	—	5,000

E661H SERIES

Features:

- * MAT'L: NYLON 66 UL 94V-2
- * MATES WITH E661 SERIES TERMINAL
- * MATES WITH E761 SERIES HOUSING

unit:mm

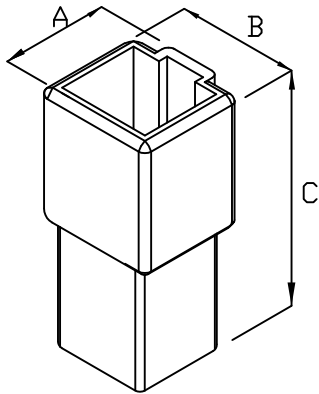

PRAT NO	A	B
E661H-01	10.0	13.5
E661H-02	18.3	13.2
E661H-03	19.9	16.5
E661H-04(2X2)	15.5	24.5
E661H-06(2X3)	15.5	31.3
E661H-08(2X4)	15.5	40.6

E661H-01



E661H-02

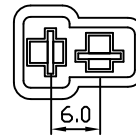

E661H-03

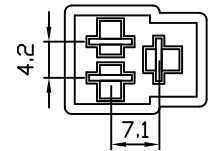

E661H-04(2X2)

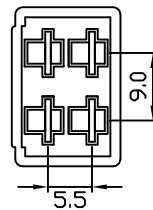

E661H-06(2X3)

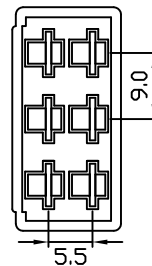

E661H-08(2X4)

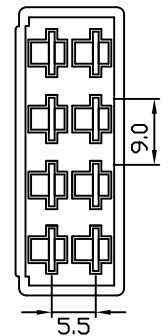

E761H SERIES

Features:

- * MAT'L: NYLON 66 UL 94V-2
- * MATES WITH E761 SERIES TERMINAL
- * MATES WITH E661 SERIES HOUSING

unit:mm

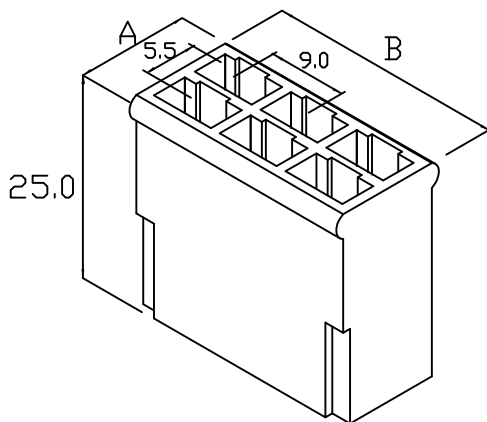

PRAT NO	A	B
E761H-01	6.5	10.0
E761H-02	15.3	10.0
E761H-03	16.5	13.0
E761H-04 (2X2)	12.0	19.0
E761H-06 (2X3)	12.0	28.0
E761H-08 (2X4)	12.0	37.0

E761H-01

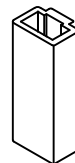

E761H-02

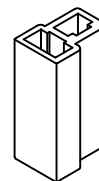

E761H-03

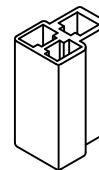

E761H-04(2X2)

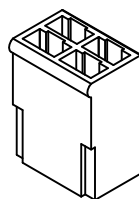

E761H-06(2X3)

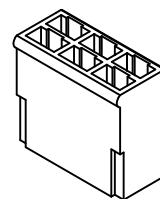

E761H-08(2X4)

