

DIP TYPE SERIES

unit:mm

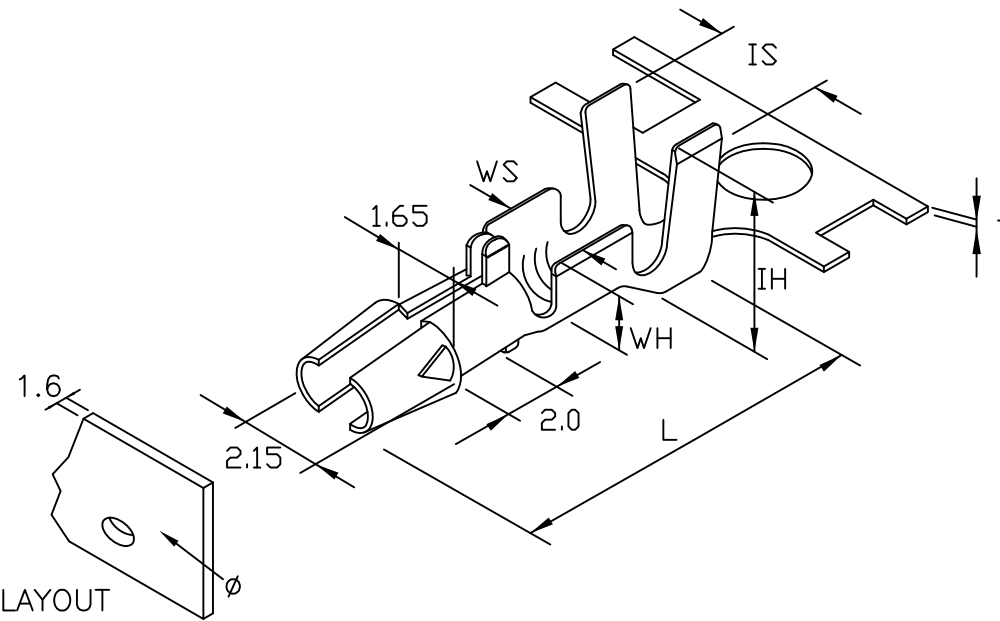

D180
D181
D186

P.C.B LAYOUT

PART/NO.	WIRE RANGE	T	L	WS	WH	IS	IH	P.C.B(φ)	C/W	P.C.B(T)	MATERIAL	FINISH
D180	AWG#20-26	0.25	10.4	2.0	1.9	3.4	3.3	φ1.8	1.55	1.6	BRASS	Tin-plated
D181	AWG#18-22	0.25	10.4	2.2	2.3	3.6	3.8	φ1.8	1.55			
D186	AWG#16-20	0.25	10.4	2.7	3.0	5.0	5.3	φ1.8	1.55			